



## 6200 Chair Operation & Installation

EN | FR

Look closer. See further.

 **HAAG-STREIT**  
RELIANCE



## SERIAL NUMBER

---

For your future reference, mark the serial number in the space provided.

**Haag-Streit USA Inc.**

3535 Kings Mills Road  
Mason, Ohio 45040-2303

(800) 787-5426

[www.haag-streit-usa.com](http://www.haag-streit-usa.com)



**MADE IN USA**

QUALITY MANAGEMENT  
SYSTEM  
REGISTERED TO  
ISO 13485:2016

## TABLE OF CONTENTS

IMPORTANT INFORMATION .....	4	4. LOCATING AND REPLACING FUSES .....	13
SAFETY SYMBOLS .....	4	4.1. Fuse Replacement .....	13
TRANSPORTATION / STORAGE CONDITIONS .....	5	TROUBLESHOOTING GUIDE .....	14
1. INTRODUCTION .....	6	CLEANING AND MAINTENANCE .....	15
TECHNICAL SPECIFICATIONS .....	6	LIMITED WARRANTY .....	17
2. INSTALLATION .....	8		
2.1. Unpacking .....	8		
2.1.1. Chair .....	8		
2.2. Assembly .....	8		
2.2.1. Headrest .....	8		
2.2.2. Power Receptacle .....	8		
3. OPERATING INSTRUCTIONS .....	9		
3.1. Stop Switch .....	9		
3.2. Chair Lift .....	9		
3.2.1. Raising & Lowering the Chair Lift with Membrane Switches .....	9		
3.2.2. Raising & Lowering the Chair Lift from the Footswitch .....	9		
3.3. Chair Top .....	10		
3.3.1. Positioning the Chair Back .....	10		
3.4. Revolving/Rotation .....	11		
3.5. Arm Movement .....	11		
3.6. Footrest .....	11		
3.7. Headrest .....	12		
3.7.1. Operation – No. 18, 22 Headrest ..	12		
3.7.2. Adjustment – No. 18, 22 Headrest .....	12		
3.7.3. Operation – No. 10 Headrest .....	12		

## IMPORTANT INFORMATION

### SAFETY SYMBOLS

Whenever you see the symbols shown below, heed their instructions! Always follow safe operating and maintenance practices.



**“DANGER” – THE DANGER SYMBOL IDENTIFIES SPECIAL INSTRUCTIONS OR PROCEDURES WHICH, IF NOT CORRECTLY FOLLOWED, COULD RESULT IN LOSS OF LIFE OR PERSONAL INJURY.**



**“DANGER” – LE SYMBOLE DANGER IDENTIFIE DES INSTRUCTIONS OU PROCÉDURES SPÉCIALES QUI, SI ELLES NE SONT PAS SUIVIES CORRECTEMENT, POURRAIENT CAUSER UNE PERTE DE VIE OU UNE BLESSURE.**



**“WARNING” – THE WARNING SYMBOL IDENTIFIES SPECIAL INSTRUCTIONS OR PROCEDURES WHICH, IF NOT CORRECTLY FOLLOWED, COULD RESULT IN PERSONAL INJURY.**



**“AVERTISSEMENT” – LE SYMBOLE AVERTISSEMENT IDENTIFIE DES INSTRUCTIONS OU PROCÉDURES SPÉCIALES QUI, SI ELLES NE SONT PAS SUIVIES CORRECTEMENT, POURRAIENT CAUSER UNE BLESSURE.**



**“CAUTION” – THE CAUTION SYMBOL IDENTIFIES SPECIAL INSTRUCTIONS OR PROCEDURES WHICH, IF NOT STRICTLY OBSERVED, COULD RESULT IN DAMAGE TO OR DESTRUCTION OF EQUIPMENT.**



**“PRÉCAUTION” – LE SYMBOLE DE PRÉCAUTION IDENTIFIE DES INSTRUCTIONS OU PROCÉDURES SPÉCIALES QUI, SI ELLES NE SONT PAS STRICTEMENT SUIVIES, POURRAIENT CAUSER UN DOMMAGE OU LA DESTRUCTION DE L’ÉQUIPEMENT.**



**“NOTE”** – Note indicates points of particular or additional information.

**“REMARQUE”** – Remarque indique des points d’intérêt particulier ou des renseignements additionnels. la note indique des remarques d’information particulière ou supplémentaire.



Type B, Applied Part

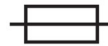

Fuse Rating Specification



Protective Earth Ground



Burn Hazard/Hot Surface



Alternating Current-AC



Safe Working Load



“Attention, Consult Accompanying Documents”



Refer to Instruction Manual/Booklet



Sitting Prohibited on Back of Chair



Not To Be Used as a Handle

## TRANSPORTATION / STORAGE CONDITIONS

Temperature: Operating:	59 to 104° F 15 to 40° C
Storage:	-22 to +140° F -30 to +60° C
Relative Humidity: Operating:	5%RH to 95%RH without condensation
Storage:	10%RH to 100%RH, including condensation
Atmospheric Pressure:	
Operating:	700hPa – 1060hPa
Storage:	500hPa – 1060 hPa

## 1. INTRODUCTION

- 1.1. This Installation and Operating Instruction contains information applicable only to the Reliance® Model 6200 Chair.
- 1.2. Should your product not perform properly, or if the product is in need of repair, or if you have any questions concerning the use and care of any Haag-Streit product, contact the Haag-Streit Distributor, where you purchased this product or contact the Technical Service Department, Haag-Streit USA, Inc., 3535 Kings Mills Road, Mason, Ohio 45040-2303, or call 800-787-5426.

**NOTE:** Always have the model number and serial number available before contacting Haag-Streit or your authorized Haag-Streit Distributor.

**REMARQUE:** Ayez toujours le numéro de modèle et le numéro de série à portée de la main avant de contacter Haag-Streit ou votre distributeur Haag-Streit autorisé.

**“CLASSIFIED BY CANADIAN STANDARDS ASSOCIATION® CSA WITH RESPECT TO ELECTRIC SHOCK, FIRE AND MECHANICAL HAZARDS ONLY IN ACCORDANCE WITH IEC 60601-1.”**

According to Clause 5 in IEC 60601-1, sec 6.8.1, this Unit is classified by the following:

- The type of protection against electric shock: EQUIPMENT energized from an external electrical power source: CLASS I EQUIPMENT
- The degree of protection against electric shock: TYPE B EQUIPMENT
- The degree of protection against harmful ingress of water: ORDINARY DEGREE
- The degree of safety of application in the presence of a FLAMMABLE ANESTHETIC MIXTURE WITH AIR or WITH OXYGEN OR NITROUS OXIDE: EQUIPMENT not suitable for use in the presence of a FLAMMABLE ANESTHETIC MIXTURE WITH AIR or WITH OXYGEN OR NITROUS OXIDE

- The mode of operation:
- Chair – 9 second on / 81 second off Duty Cycle.
- Normal Use – 6240 duty cycle/year; 3 patients per hour, 8 hours per day, 5 days a week, 52-week calendar year.



**WARNING: TO PREVENT FIRE OR ELECTRICAL SHOCK HAZARD, DO NOT EXPOSE THIS EQUIPMENT TO RAIN OR MOISTURE.**



**AVERTISSEMENT: POUR ÉVITER UN INCENDIE OU UN RISQUE DE CHOC ÉLECTRIQUE, N'EXPOSEZ PAS CET ÉQUIPEMENT À LA PLUIE OU À L'HUMIDITÉ.**

## TECHNICAL SPECIFICATIONS

### Rating for 120V Low Voltage Chair

This equipment is rated Class I, Type B			
Equipment		Model	
Low Voltage Chair		6200	
Volts	Hertz	Amps	
120V	50/60	9.0	
Class I	Type B		



### Rating for 220-240V Low Voltage Chair

This equipment is rated Class I, Type B			
Equipment		Model	
Low Voltage Chair		6200	
Volts	Hertz	Amps	
220 - 240V	50/60	4.0	
Class I	Type B		



## IMPORTANT USER WARNINGS



**WARNING: EXPLOSION HAZARD. THIS EQUIPMENT MUST NOT BE USED IN THE PRESENCE OF FLAMMABLE ANESTHETICS.**



**AVERTISSEMENT: RISQUE D'EXPLOSION. CET ÉQUIPEMENT NE DOIT PAS ÊTRE UTILISÉ EN PRÉSENCE D'ANESTHÉSQUES INFLAMMABLES.**

## POTENTIAL ELECTROMAGNETIC OR OTHER INTERFERENCE

This equipment generates, uses and can radiate radio frequency energy and, if not installed and used in accordance with the instructions, may cause harmful interference to other devices in the vicinity. However, there is no guarantee that interference will not occur in a particular installation.

If this equipment does cause harmful interference to other devices, which can be determined by turning the equipment off and on, the user is encouraged to try to correct the interference by one or more of the following measures:

- Reorient or relocate the receiving device.
- Increase the separation between equipment.
- Connect the equipment into an outlet on a circuit different from that to which the other device(s) are connected.
- Consult the manufacturer or field service technician for help.



**WARNING: STORAGE OF THIS EQUIPMENT BELOW 40°F (4.4°C) WILL CAUSE THE HYDRAULIC OIL TO BECOME THICK. THIS MAY CAUSE UNUSUAL NOISES WHEN THE BASE MOTOR IS OPERATED. IT IS RECOMMENDED THAT THE EQUIPMENT STAY AT A TEMPERATURE OF 60°F (15.6°C) OR ABOVE FOR AT LEAST 8 HOURS BEFORE OPERATING.**



**AVERTISSEMENT: L'ENTREPOSAGE DE CET ÉQUIPEMENT À MOINS DE 4,4°C (40°F) FERA EN SORTE QUE L'HUILE HYDRAULIQUE DEVIENDRA ÉPAISSE. CECI POURRAIT CAUSER DES BRUITS INHABITUELS LORSQUE LE MOTEUR DE LA BASE FONCTIONNE. ON RECOMMANDE QUE L'ÉQUIPEMENT DEMEURE À UNE TEMPÉRATURE DE 15,6°C (60°F) OU PLUS DURANT AU MOINS 8 HEURES AVANT DE L'UTILISER.**

## 2. INSTALLATION



**WARNING: INSTALLATION & REPAIRS MAY ONLY BE PERFORMED BY TRAINED TECHNICAL PERSONNEL.**



**AVERTISSEMENT: L'INSTALLATION ET LES RÉPARATIONS NE DOIVENT ÊTRE EFFECTUÉES QUE PAR DU PERSONNEL TECHNIQUE FORMÉ.**

### 2.1. UNPACKING

#### 2.1.1. Chair

**2.1.1.1.** Cut the shipping bands, open the top of the shipping carton, and remove all packing material and boxes that can be easily reached. Remove (4) nuts and remove both base clamping boards.

**2.1.1.2.** It is recommended that the skid be positioned as close as possible to the desired chair location.

**2.1.1.3.** Remove at least two small shipping blocks stapled to the top of the skid. The chair can now be slid and/or tipped from the skid onto the floor.



**WARNING: ENSURE CHAIR IS PLACED ON A FLAT FLOOR FOR SUFFICIENT STABILITY.**



**AVERTISSEMENT: S'ASSURER QUE LA CHAISE EST PLACÉE SUR UNE SURFACE PLANE ET DE NIVEAU AFIN D'ASSURER UNE STABILITÉ SUFFISANTE.**

**2.1.1.4.** Do not lift the chair by the upper structure. However, the chair may be tipped or slid into position by pushing or pulling on the upper structure.



**WARNING: NEVER USE THE HEADREST AS A HANDLE WHEN REMOVING THE CHAIR FROM THE SKID OR DURING TRANSPORT TO ITS FINAL LOCATION.**



**AVERTISSEMENT: NE JAMAIS UTILISER L'APPUIE-TÊTE COMME POIGNÉE LORS DU RETRAIT DU FAUTEUIL DE LA PALETTE OU PENDANT SON TRANSPORT VERS SON EMPLACEMENT FINAL.**

**2.1.1.5.** With the chair in position, remove all remaining paper pads, plastic, tape, strings, etc.

**2.1.1.6.** Inspect the chair for any damage from transportation before proceeding.



**WARNING: NEVER OPERATE DEFECTIVE EQUIPMENT. CONTACT HAAG-STREIT TECH SERVICE IMMEDIATELY.**



**AVERTISSEMENT: NE JAMAIS FAIRE FONCTIONNER UN ÉQUIPEMENT DÉFECTUEUX. CONTACTEZ IMMÉDIATEMENT LE SERVICE TECHNIQUE HAAG-STREIT.**

### 2.2. Assembly

#### 2.2.1. Headrest

**2.2.1.1.** Remove the headrest from its carton and mount it into position onto the chair back. Using the proper hex key wrench, tighten the cap screw to clamp the headrest securely into its mounting bracket.



**NOTE:** Intended use of the Headrest is designed for comfort and support during normal seated use only.

**REMARQUE:** L'utilisation prévue de l'appuie-tête est conçue uniquement pour offrir confort et soutien dans des conditions normales d'utilisation en position assise.

#### 2.2.2. Power Receptacle

**2.2.2.1.** Locate the footswitch assembly, chair control cable, and the power cord assembly. Refer to Figure 1 for receptacle location and attach all cables.

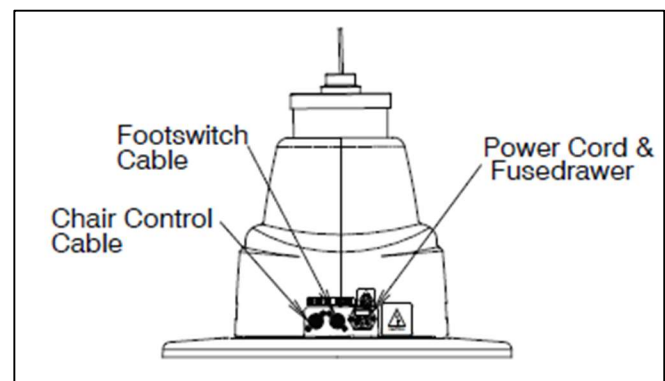

**FIGURE 1  
BASE**

2.2.2.2. To disconnect power to Chair, unplug power cord from Instrument Stand or from wall receptacle.

**NOTE:** If this chair is purchased in conjunction with a Reliance® instrument stand, the chair control cable supplied will provide proper operation. Refer to the instrument stand manual for connection to the stand.

**REMARQUE:** Si cette chaise est achetée avec un support à instruments Reliance®, le câble de commande de la chaise fourni permettra un fonctionnement adéquat. Se référer au manuel du support d'instrument pour savoir comment faire la connexion au support.

### 3. OPERATING INSTRUCTIONS

**CAUTION: CAUTION SHOULD BE TAKEN TO ENSURE THERE ARE NO OBSTRUCTIONS (INSTRUMENTS, TRAYS, TABLES) IMPEDING MOVEMENT OF THE CHAIR.**

**PRÉCAUTION: ON DEVRAIT FAIRE ATTENTION POUR S'ASSURER QU'IL N'Y A PAS D'OBSTRUCTIONS (INSTRUMENTS, PLATEAUX, TABLES) EMPÊCHANT LE MOUVEMENT DE LA CHAISE.**

**WARNING: ONLY TRAINED/QUALIFIED PERSONNEL SHOULD OPERATE CHAIR.**

**AVERTISSEMENT: SEUL LE PERSONNEL FORMÉ ET QUALIFIÉ DOIT UTILISER LA CHAISE.**

Each time main power is applied to the chair, the circuit board inside the chair will respond with a one second beep. The beep indicates the electronics are functioning properly.

#### 3.1. Stop Switch

3.1.1. Depressing the STOP switch on either side of the chair back will STOP ALL movement of the chair. The STOP switch is shaped like a stop sign and may be either RED or ORANGE in color. It is located above the text "STOP". (Refer to Figure 2).

### 3.2. Chair Lift

#### 3.2.1. Raising & Lowering the Chair with Membrane Switches

- The chair lift may be raised or lowered by Membrane Switches on either side of the chair back (Figure 2).
- To raise the chair lift from these switches, depress the triangular-shaped UP arrow located ABOVE the text "BASE". This is called the RAISE BASE switch.
- To lower the chair lift, depress the triangular-shaped DOWN arrow located BELOW the text "BASE". This is called the LOWER BASE switch.

**NOTE:** By design, the motion of the Chair will STOP when the RAISE or LOWER BASE switch is released.

**REMARQUE:** Selon la conception initiale, le mouvement de la chaise S'ARRÊTE lorsque l'interrupteur RAISE (LEVER) ou LOWER (BAISSER) la base est relâché.

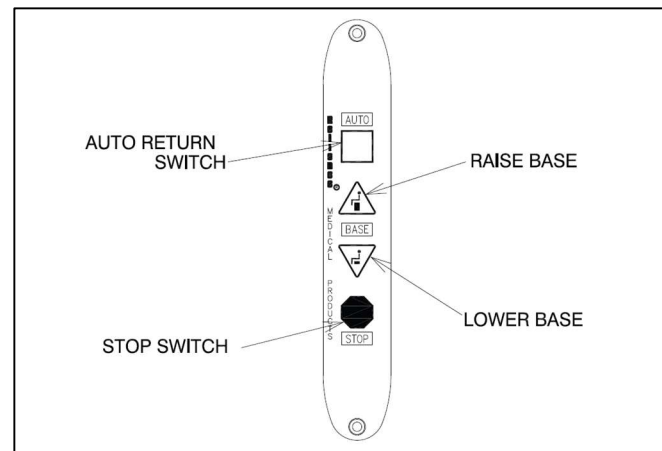

FIGURE 2  
MEMBRANE SWITCH

#### 3.2.2. Raising & Lowering the Chair from the Footswitch

- For operation from the footswitch (Figure 3), depress the right side of the pedal to raise the chair lift.
- Depress the left side of the pedal to lower the chair lift.

**NOTE:** By design, the motion of the Chair will STOP when the RAISE or LOWER BASE switch is released.

**REMARQUE:** Selon la conception initiale, le mouvement de la chaise S'ARRÊTE lorsque l'interrupteur RAISE (LEVER) ou LOWER (BAISSER) la base est relâché.

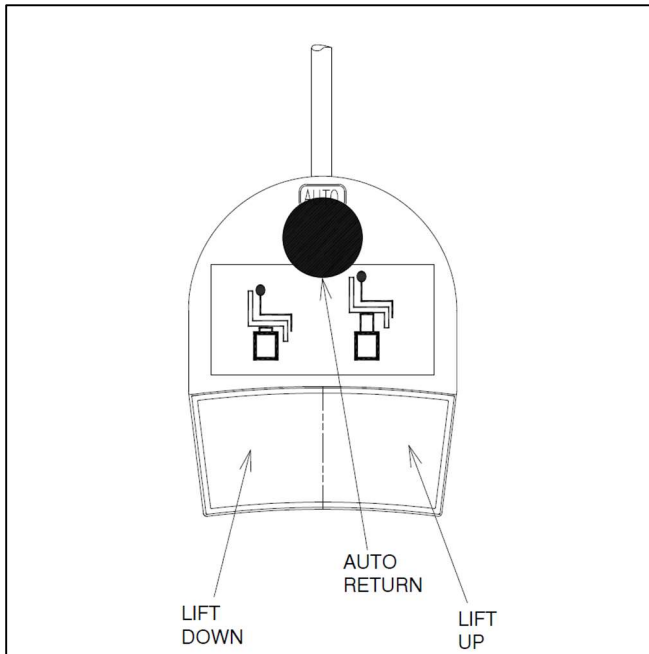
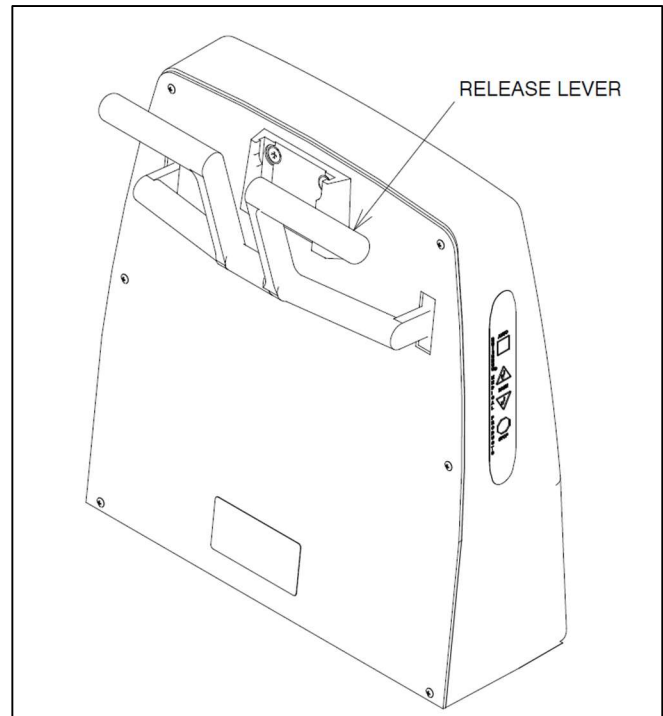

**FIGURE 3**  
**FOOTSWITCH OPERATION**

### 3.3. Chair Top

#### 3.3.1. Positioning the Chair Back

- The chair back may be reclined or raised by either pushing downward or pulling upward on the release lever (Figure 4).
- If the chair is equipped with an articulating leg rest, the footrest and apron will rise when the back is reclined.
- In the extreme reclined position these surfaces form a flat table.



**FIGURE 4**  
**RELEASE LEVER**

**CAUTION: THIS EXAM CHAIR IS DESIGNED FOR USE IN A SPECIFIC POSITION CALLED THE INTENDED USE POSITION. PRIOR TO RECLINING A PATIENT, ENSURE THE CHAIR BACK IS ALIGNED WITH THE CHAIR'S POWER RECEPTACLE AND THAT THE CHAIR SWIVEL IS LOCKED. THE SAFE WORKING LOAD IS REDUCED IF THE CHAIR IS SWIVELED AWAY FROM THIS INTENDED USE POSITION, AND MAY RESULT IN INSUFFICIENT STABILITY.**



**PRÉCAUTION: CETTE CHAISE D'EXAMEN EST CONÇUE POUR UTILISATION DANS UNE POSITION SPÉCIFIQUE APPELÉE LA POSITION D'UTILISATION PRÉVUE. AVANT D'INCLINER UN PATIENT, ASSUREZ-VOUS QUE LE DOSSIER DE LA CHAISE EST ALIGNÉ AVEC LE RÉCEPTACLE D'ALIMENTATION DE LA CHAISE ET QUE LE PIVOT DE LA CHAISE EST VERROUILLÉ. LA CHARGE DE TRAVAIL SÉCURITAIRE EST RÉDUITE SI LA CHAISE EST TOURNÉE HORS DE SA POSITION D'UTILISATION PRÉVUE ET CELA POURRAIT CAUSER UNE STABILITÉ INSUFFISANTE.**





**CAUTION: THIS EXAM CHAIR IS DESIGNED FOR USE WITH A SPECIFIC MAXIMUM PATIENT WEIGHT (FOUND ON PRODUCT LABEL) AS A STATIC (NON-MOVING) LOAD. SUDDEN WEIGHT SHIFTS OR IMPACT LOADS CAN EXCEED THE SAFE STATIC LOAD RATING OF THE CHAIR, AND MAY RESULT IN INSUFFICIENT STABILITY.**



**PRÉCAUTION: CETTE CHAISE D'EXAMEN EST CONÇUE POUR UTILISATION AVEC UN POIDS DE PATIENT MAXIMUM SPÉCIFIQUE (FIGURANT SUR L'ÉTIQUETTE DU PRODUIT) COMME CHARGE STATIQUE (SANS MOUVEMENT). LES DÉPLACEMENTS DE POIDS SOUDAINS OU LES CHARGES DYNAMIQUES PEUVENT EXCÉDER LA NORME DE CHARGE STATIQUE SÉCURITAIRE DE LA CHAISE, CE QUI POURRAIT CAUSER UNE STABILITÉ INSUFFISANTE.**



**CAUTION: THIS EXAM CHAIR IS DESIGNED FOR USE WITH A PATIENT PROPERLY POSITIONED IN THE CHAIR. PRIOR TO RECLINING THE CHAIR, ENSURE THAT THE PATIENT IS SEATED IN THE CHAIR AND THAT THE PATIENT POSITION DOES NOT MOVE TO AN EXTREME POSITION EITHER TOWARD THE HEAD OF THE CHAIR OR TOWARD THE FOOT OF THE CHAIR, SINCE THIS MAY RESULT IN INSUFFICIENT STABILITY.**



**PRÉCAUTION: CETTE CHAISE D'EXAMEN EST CONÇUE POUR UTILISATION AVEC UN PATIENT CORRECTEMENT POSITIONNÉ DANS LA CHAISE. AVANT D'INCLINER LA CHAISE, ASSUREZ-VOUS QUE LE PATIENT EST ASSIS DANS LA CHAISE ET QUE LA POSITION DU PATIENT NE SE DÉPLACE PAS VERS UNE POSITION EXTRÊME SOIT VERS LA TÊTE, SOIT VERS LE PIED DE LA CHAISE, PUISQUE CELA POURRAIT CAUSER UNE STABILITÉ INSUFFISANTE.**

### **3.4. Revolving/Rotation**

**3.4.1.** The chair upper structure may be revolved 350°, with a built-in stop to prevent continuous rotation. The lock for revolving is controlled by a hand lever with chrome plated knob located below the seat at the center and on either side. Push the lever down to release the lock and lift to apply the lock.

### **3.5. Arm Movement**

**3.5.1.** The chair arms may be raised to provide better access to the patient or to permit entrance to or exit from the chair.

**3.5.2.** The movements of both arms are identical and completely independent of each other.

**3.5.3.** To raise an arm, push rearward on the middle joint of the arm support link while raising upward on the arm. A stop limits upward motion of the arm to a point parallel to the plane of the back. Lowering the arm automatically locks it in place against vertical motion in either direction.

### **3.6. Footrest**

**3.6.1.** The footrest may be retracted by lifting near its outer edge. When fully retracted the footrest will stay in place.

### 3.7. Headrest

3.7.1. The No. 18 headrest is the standard headrest for the Model 6200 Chair.



**WARNING: IF THE NO. 18 HEADREST RECEIVES AN IMPACT OR STRIKES AN OBJECT WITH FORCE CONTACT HAAG-STREIT TECH SERVICE IMMEDIATELY.**



**AVERTISSEMENT: SI L'APPUIE-TÊTE # 18 REÇOIT UN CHOC OU FRAPPE UN OBJET AVEC FORCE, CONTACTEZ IMMÉDIATEMENT LE SERVICE TECHNIQUE HAAG-STREIT.**

#### 3.7.2. Operation – No. 18, 22 Headrest

3.7.2.1. The No. 18, 22 headrest is designed so it can be operated with just one hand. To unlock, squeeze the clear plastic actuator into lock housing. This will allow both pivots of the articulating arm to rotate so the headrest can be moved to a new desired position. Once in the new position, release the actuator. Make sure the actuator expands to its original position fully exposing black dot on handle to insure a positive lock. The headrest pad is free to rotate at all times (See Figure 5).

#### 3.7.3. Adjustment – No. 18, 22 Headrest

3.7.3.1. There are three adjustments provided on the No. 18, 22 headrest. The first is the tension on the pad rotation. By tightening the two hex acorn nuts on the pad pivots with a 3/8" open end wrench, the tension will be increased.

3.7.3.2. To adjust the drag on the pivots of the articulating arm, loosen the set screw in the center of the pivot (Figure 5, item 1) with a 3/32" hexagon key wrench. Next, tighten the pivot screw on the other side of the pivot, with a 1/8" hexagon key wrench. Now, retighten the set screw to retain the pivot screw at the new adjustment. Either pivot may be adjusted.

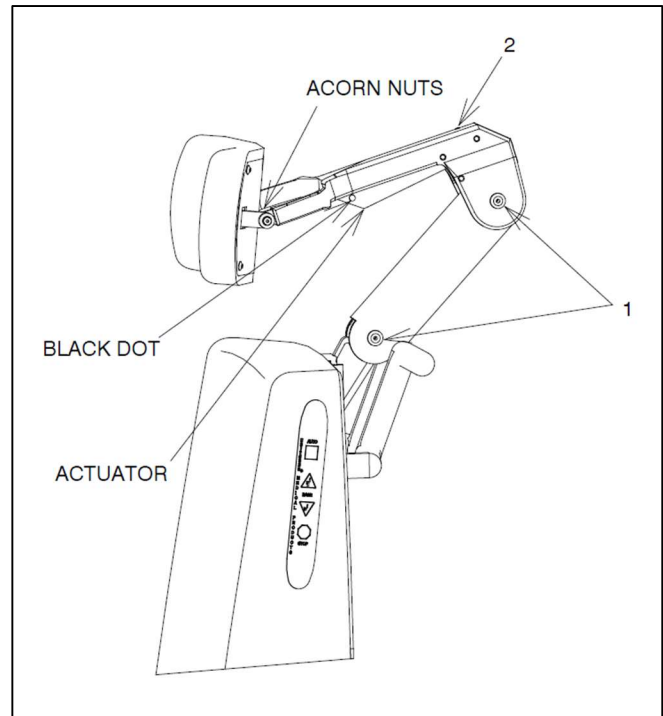

**FIGURE 4  
NO. 18, 22 HEADREST**

3.7.3.3. The third adjustment is for proper clearance of the black dot to indicate that the headrest is properly locked. If the dot does not fully clear the lock housing when the headrest is lock securely, turn the set screw located at the top of the lock housing (Figure 5, item 2) counterclockwise until the dot on the actuator is fully exposed.

#### 3.7.4. Operation – No. 10 Headrest

3.7.4.1. The No. 10 headrest has a fixed, rigid upholstered backboard which supports a sliding, center pillow section. For patient comfort simply move this pillow to a desired position.

#### 4. LOCATING AND REPLACING FUSES

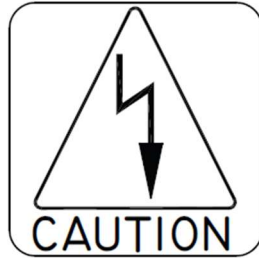
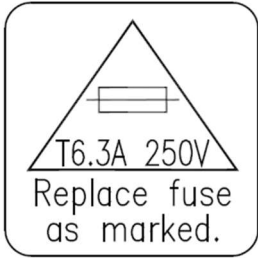

**WARNING: DISCONNECT EQUIPMENT FROM MAIN INPUT POWER BEFORE PROCEEDING WITH ELECTRICAL INSPECTIONS OR MAINTENANCE.**



**AVERTISSEMENT: DÉCONNECTEZ L'ÉQUIPEMENT DE L'ALIMENTATION ÉLECTRIQUE PRINCIPALE AVANT DE PROCÉDER À DES INSPECTIONS ÉLECTRIQUES OU À DE L'ENTRETIEN.**



**CAUTION: REPLACE FUSE(S) AS MARKED. ALL FUSES MUST BE REPLACED WITH A FUSE OF THE SAME SIZE AND RATING. REFER TO THE WIRE DIAGRAMS AT THE END OF THIS MANUAL.**



**PRÉCAUTION: REMPLACEZ LE(S) FUSIBLE(S) COMME INDIQUÉ. TOUS LES FUSIBLES DOIVENT ÊTRE REMPLACÉS PAR UN FUSIBLE DE LA MÊME DIMENSION ET DE LA MÊME VALEUR. SE RÉFÉRER AUX SCHÉMAS DE CÂBLAGE À LA FIN DE CE MANUEL.**

The chair contains two fuses located inside the AC Input Module in the Base Assembly.

#### 4.1. Fuse Replacement (AC Input Module)

**4.1.1.** Unplug the power cord from the AC power input module. Referring to Figure 6, locate tab. With a tool similar to a small common screwdriver placed under tab, pry fuse drawer out. Remove the drawer by pulling it out with your fingers.

**4.1.2.** To remove fuses from fuse drawer, tilt fuses in direction of arrows as shown in Figure 6. Examine the fuses, replace as necessary.

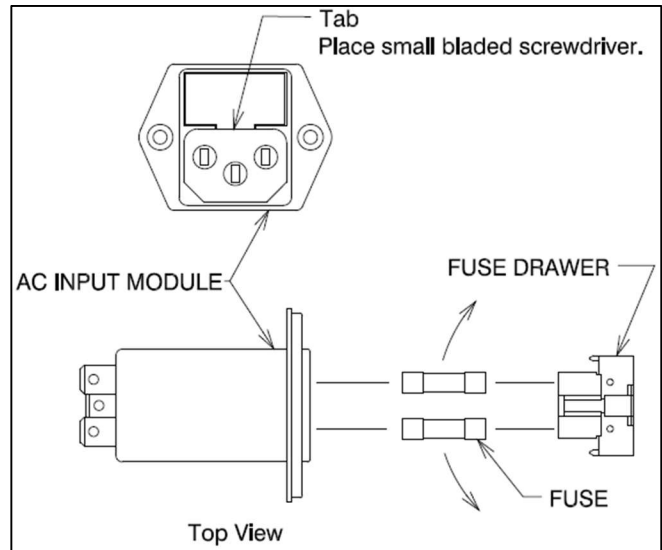

**FIGURE 6  
AC INPUT MODULE**



**CAUTION: TO AVOID A BIND OF THE FUSE DRAWER WITHIN THE AC INPUT MODULE, NEVER INSTALL THE FUSE DRAWER INTO THE AC INOUT MODULE WITHOUT FUSES.**



**PRÉCAUTION: POUR ÉVITER QUE LE TIROIR À FUSIBLE RESTE BLOQUÉ DANS LE MODULE D'ENTRÉE CA, N'INSTALLEZ JAMAIS LE TIROIR À FUSIBLE À L'INTÉRIEUR DU MODULE D'ENTRÉE CA SANS FUSIBLES.**

## TROUBLESHOOTING GUIDE

PROBLEM	PROBLEM CAUSE	SOLUTION
CHAIR WILL NOT OPERATE.	<ol style="list-style-type: none"> <li>1) POWER CORD NOT PLUGGED IN.</li> <li>2) NO AC POWER AT WALL RECEPTACLE.</li> <li>3) BLOWN LINE FUSE.</li> </ol>	<ol style="list-style-type: none"> <li>1) CHECK ALL WIRING CONNECTIONS.</li> <li>2) RESTORE OUTLET POWER.</li> <li>3) REPLACE FUSE.</li> </ol>
OUTLET POWER OK, BUT NO BEEP IS HEARD WHEN POWER IS APPLIED.	<ol style="list-style-type: none"> <li>1) BLOWN LINE FUSE.</li> <li>2) LOOSE WIRING IN BASE.</li> <li>3) OTHER.</li> </ol>	<ol style="list-style-type: none"> <li>1) REPLACE FUSE.</li> <li>2) CHECK ALL WIRING CONNECTIONS.</li> <li>3) CONTACT FACTORY.</li> </ol>
FOOTSWITCH FUNCTIONS NOT OPERATING.	<ol style="list-style-type: none"> <li>1) FOOTSWITCH CORD NOT CONNECTED.</li> </ol>	<ol style="list-style-type: none"> <li>1) CHECK ALL INTERNAL AND EXTERNAL FOOTSWITCH WIRING.</li> </ol>
BACKSWITCH FUNCTIONS NOT OPERATING.	<ol style="list-style-type: none"> <li>1) DAMAGED OR DISCONNECTED WIRES IN CHAIR BACK, UNDER CHAIR SEAT, OR IN CHAIR BASE.</li> </ol>	<ol style="list-style-type: none"> <li>1) CHECK ALL WIRING CONNECTIONS.</li> </ol>
CHAIR BASE WILL NOT STAY UP.	<ol style="list-style-type: none"> <li>1) SOLENOID VALVE NOT CLOSED (DIRT IN VALVE).</li> <li>2) CONSTANT POWER APPLIED TO SOLENOID.</li> <li>3) OTHER</li> </ol>	<ol style="list-style-type: none"> <li>1) REPAIR OR REPLACE SOLENOID VALVE.</li> <li>2) CHECK FOR SWITCHES STUCK "CLOSED".</li> <li>3) CONTACT FACTORY.</li> </ol>
CHAIR BASE WILL NOT LOWER.	<ol style="list-style-type: none"> <li>1) NO POWER TO PUMP MOTOR ASS'Y.</li> <li>2) SOLENOID COIL BURNED-OUT.</li> <li>3) OTHER</li> </ol>	<ol style="list-style-type: none"> <li>1) CHECK FOR VOLTAGE.</li> <li>2) REPLACE SOLENOID COIL.</li> <li>3) CONTACT FACTORY</li> </ol>
CHAIR BASE WILL NOT RAISE. PUMP MOTOR DOES NOT RUN.	<ol style="list-style-type: none"> <li>1) NO POWER TO PUMP MOTOR ASS'Y.</li> <li>2) UP-LIMIT SWITCH STUCK "OPEN".</li> <li>3) PUMP MOTOR BURNED-OUT.</li> <li>4) OTHER.</li> </ol>	<ol style="list-style-type: none"> <li>1) CHECK FOR VOLTAGE.</li> <li>2) RE-ADJUST OR REPLACE SWITCH.</li> <li>3) REPLACE PUMP MOTOR ASS'Y.</li> <li>4) CONTACT FACTORY.</li> </ol>
CHAIR BASE WILL NOT RAISE. PUMP MOTOR RUNS.	<ol style="list-style-type: none"> <li>1) SOLENOID VALVE NOT CLOSED (DIRT IN VALVE).</li> <li>2) CONSTANT POWER APPLIED TO SOLENOID.</li> <li>3) OTHER.</li> </ol>	<ol style="list-style-type: none"> <li>1) REPAIR OR REPLACE SOLENOID VALVE.</li> <li>2) CHECK FOR SWITCHES STUCK "CLOSED".</li> <li>3) CONTACT FACTORY.</li> </ol>
BASE "STUTTERS" DURING ASCENT.	<ol style="list-style-type: none"> <li>1) HYDRAULIC FLUID LEVEL IS LOW.</li> </ol>	<ol style="list-style-type: none"> <li>1) CONTACT DEALER OR FACTORY FOR INFORMATION ON ADDING OIL.</li> </ol>
CHAIR BASE WILL NOT RAISE OR LOWER FROM FLOOR UNIT.	<ol style="list-style-type: none"> <li>1) CHAIR CONTROL CABLE NOT PLUGGED IN.</li> <li>2) BLOWN FUSE IN CHAIR BASE.</li> </ol>	<ol style="list-style-type: none"> <li>1) CHECK CABLE CONNECTIONS AT STAND CHAIR.</li> <li>2) REPLACE FUSE.</li> </ol>
CHAIR TOP "WOBBLES" ON CHAIR BASE.	<ol style="list-style-type: none"> <li>1) LOCK NUT IS LOOSE (UNDER SEAT BOARD).</li> </ol>	<ol style="list-style-type: none"> <li>1) TIGHTEN LOCK NUT.</li> </ol>
CHAIR BACK RECLINES FULLY WITHOUT HANDLE BEING ACTIVATED.	<ol style="list-style-type: none"> <li>1) BACK SPRING FAILURE.</li> </ol>	<ol style="list-style-type: none"> <li>1) ADJUST GAS SPRING.</li> <li>2) REPLACE GAS SPRING.</li> </ol>
CHAIR BACK SPONGY WHEN PATIENT PUTS PRESSURE ON CHAIR BACK.	<ol style="list-style-type: none"> <li>1) BACK SPRING FAILURE.</li> </ol>	<ol style="list-style-type: none"> <li>1) REPLACE GAS SPRING.</li> </ol>

## CLEANING AND MAINTENANCE

### Cleaning the Upholstery

When cleaning upholstery, it is suggested that you use all recommended commercial cleaning agents in an inconspicuous spot to check for potential damage to the upholstery material before applying to the entire area to be cleaned.

#### Day to Day Soil:

Remove ordinary dirt and smudges with a mild soap and warm water solution. Dry with a soft, lint-free cloth or towel. For more difficult stains, use of a stronger detergent is recommended; however, follow the detergent manufacturer's instructions closely.

#### Disinfecting Material:

In order to disinfect, use a 1:9 solution of bleach and water (1 part bleach to 9 parts water). Wipe surface with damp cloth then rinse with water immediately, using a damp cloth.

#### Special Cleaning Problems:

The following methods are recommended to clean stains on PreFixx-protected vinyl upholstery. Most stains will be removed when these cleaning agents are used in the following order.

**Type 1 Cleaners:** Non-abrasive household cleaners to be used with water and a soft cloth.

- Formula 409® All-Purpose Spray Cleaner.
- Fantastik® Spray Cleaner.
- Other similar household cleaners and bleaches.

**Type 2 Cleaners:** Solvent-type cleaner to be liberally applied with a soft cloth. Dry area with another cloth, rinse with clean water and dry.

- Rubbing alcohol (isopropyl alcohol).
- Lighter fluid (naphtha).

**Type 3 Cleaners:** Strong, active solvent cleaners such as nail polish remover (acetone/water) to be applied with a soft cloth. Stain should be removed with less than six (6) rubs; if stain persists after six rubs, contact

manufacturer. Dry area with another cloth, rinse with clean water and dry.



**CAUTION: THESE SOLVENTS ARE HIGHLY FLAMMABLE. EXERCISE PROPER CARE IN CLEANING AND NOTIFY PERSONNEL IN AREA OF DANGER. WEAR RUBBER GLOVES DURING ALL CLEANING ACTIVITY. USE CAUTION IN CLEANING AROUND BUTTONS, STITCHING AND WOODEN OR OTHER DECORATIVE TRIM, SINCE THESE SOLVENTS COULD SERIOUSLY DAMAGE SUCH AREAS.**



**PRÉCAUTION: CES SOLVANTS SONT EXTRÊMEMENT INFLAMMABLES. FAITES TRÈS ATTENTION LORS DU NETTOYAGE ET AVISEZ LE PERSONNEL DANS LA ZONE DE TOUT DANGER. PORTEZ DES GANTS DE CAOUTCHOUC DURANT TOUTE ACTIVITÉ DE NETTOYAGE. FAITES ATTENTION EN NETTOYANT AUTOUR DES BOUTONS, DES COUTURES ET AUTRES FINITIONS DE BOIS OU DÉCORATIVES, PUISQUE CES SOLVANTS POURRAIENT ENDOMMAGER SÉRIEUSEMENT CES ENDOITS.**

### Cleaning Painted Surfaces

Painted metal surfaces are covered with a durable powder coat paint which is resistant to scratching and scuffing. Painted surfaces may be cleaned with a clean cloth dampened with mild, soapy water or equivalent household spray cleaner.

### Recommended Infection Control Products

The following Infection Control Products have been tested on the equipment and will not cause damage to upholstery, painted surfaces or plastic covers:

- Cavicide® Hospital Disinfectant.
- Precise® Hospital Foam Cleaner Disinfectant.



**WARNING: REFER TO LOCAL OR HEALTHCARE PROFESSION GUIDELINES FOR SELECTING EFFECTIVE INFECTION CONTROL PRODUCTS.**



**AVERTISSEMENT:** SE RÉFÉRER AUX DIRECTIVES LOCALES OU DES PROFESSIONS DE LA SANTÉ POUR SÉLECTIONNER DES PRODUITS DE CONTRÔLE D'INFECTION EFFICACES.



**CAUTION:** FOLLOW MANUFACTURER'S DIRECTIONS FOR CONCENTRATION AND APPLICATION OF DISINFECTING CLEANER. AVOID PROLONGED APPLICATION OF ANY DISINFECTANT/CLEANER PRODUCTS, BECAUSE THEY MAY CAUSE STAINING OR DISCOLORATION OF MATERIAL.



**PRÉCAUTION:** SUIVEZ LES INSTRUCTIONS DU FABRICANT POUR LA CONCENTRATION ET L'APPLICATION DE NETTOYEURS DÉSINFECTANTS. ÉVITEZ UNE APPLICATION PROLONGÉE DE TOUT PRODUIT DÉSINFECTANT/NETTOYANT, PARCE QUE CEUXCI POURRAIENT CAUSER DES TACHES OU UNE DÉCOLORATION DU MATÉRIEL.



**NOTE:** Equipment should be cleaned as needed or per local or healthcare profession guidelines.

**REMARQUE:** L'équipement devrait être nettoyé au besoin ou selon les directives locales ou celles des professions de la santé.



**WARNING:** TO AVOID BIOLOGICAL HAZARDS WHEN EQUIPMENT HAS REACHED THE END OF ITS USEFUL LIFE, DISPOSE OF EQUIPMENT PER LOCAL REGULATIONS OR HEALTHCARE PROFESSION GUIDELINES.



**AVERTISSEMENT:** POUR ÉVITER LES RISQUES BIOLOGIQUES LORSQUE L'ÉQUIPEMENT A ATTEINT LA FIN DE SA VIE UTILE, DISEPOSEZ DE L'ÉQUIPEMENT SELON LES RÉGLEMENTATIONS LOCALES OU LES DIRECTIVES DES PROFESSIONS DE LA SANTÉ.



**NOTE:** To ensure a long service life, the device should be cleaned as described. It is also recommend having the device inspected by an authorized service technician annually.

**REMARQUE:** Pour assurer une longue durée de vie, l'appareil doit être nettoyé comme décrit. Il est également recommandé de faire inspecter l'appareil par un technicien d'entretien autorisé chaque année.

## LIMITED WARRANTY

The Reliance® product must be used only for the purposes and in the manner described in the literature distributed with the product. The products are warranted against defective materials and workmanship for a period of two (2) years from date of installation. Products or parts thereof will be repaired or replaced as required at Haag-Streit USA, Inc. Such repair or replacement shall be the sole remedy under this warranty. This warranty extends only to the original purchaser from an authorized Haag-Streit dealer and is subject to the following conditions:

1. The warranty card must be completed and returned to Haag-Streit USA, Inc. within two (2) weeks from the date of installation.
2. Installation and servicing of the products must be performed by trained Haag-Streit USA, Inc. equipment dealer service personnel in accordance with the appropriate instruction manual for the products. Warranty will be voided if installation is performed by a non-authorized individual.
3. The products have not sustained breakage or other types of damage due to accident or misuse.
4. This warranty will not apply to Reliance® products which have had the serial number removed, altered or effaced.

**EXCEPT FOR THE EXPRESS WARRANTY SET FORTH ABOVE, HAAG-STREIT DOES NOT GRANT ANY WARRANTIES, EITHER EXPRESS OR IMPLIED, INCLUDING IMPLIED WARRANTIES OF MERCHANTABILITY OR FITNESS FOR A PARTICULAR USE.**

Haag-Streit USA, Inc. neither assumes nor authorizes any person to assume for it, any other liability in connection with the sale and use of its products.

**REMEDIES ARE LIMITED EXCLUSIVELY TO REPAIR OR REPLACEMENT OF PARTS. HAAG-STREIT USA, INC. EXPRESSLY DISCLAIMS LIABILITY FOR INCIDENTAL OR CONSEQUENTIAL DAMAGE RESULTING FROM THE USE OF THE EQUIPMENT.**

Claims covered by this warranty will be honored when presented within one (1) month from discovery of a defect.



**MADE IN USA**

**Haag-Streit USA, Inc  
3535 Kings Mills Road  
Mason, Ohio 45040-2303 USA  
(800) 787-5426  
(Customer / Technical Service)  
(513) 398-3937  
<http://www.haag-streit-usa.com>**

**P/N 27168 REV H  
© Copyright 2006  
Revised 04-2026-10014**